

A. A. Tarelin, Associate Member of the NASU

V. H. Mykhailenko, Candidate of Technical Sciences

O. V. Antonov,

A. A. Tarelin, Candidate of Technical Sciences

A. Podgorny Institute of Mechanical Engineering Problems of NASU, Kharkiv, Ukraine, e-mail: port342017@gmail.com

Ключові слова: шахтні води, пом'якшення, електромембранна обробка, демінералізація, зворотний осмос, випарювання з кристалізацією.

UDC 622.5:66.065.31

RESOURCE-SAVING COMPLEX FOR MINE WATER DEMINERALIZATION

Проаналізовано існуючі технології очищення шахтних вод. Показано, що здебільшого їх піддають лише освітленню і механічному очищенню. Очищені таким чином шахтні води мають підвищену мінералізацію і при скиданні у поверхневі водойми забруднюють їх. Запропоновано комплексну безстічну технологію глибокої переробки шахтних вод. Технологія полягає в їхній демінералізації і виділенні домішок як товарних продуктів для використання в будівельній промисловості, виробництві скла, комунальному господарстві та ін. За результатами розробки виконаний проект (стадія II) комплексу безстічної переробки води для шахти «Любельська», ведеться підготовка до випуску робочої документації.

Introduction

All mining works are accompanied by the formation of large amounts of saline drainage waters, which are usually discharged into the natural gulches of mining regions, contaminating surface water. These waters are a mixture of aquifer waters, occurring as the excavation depth increases. The experience of exploitation of the existing mines shows that the average salinity of mine waters tends to increase. So, in the early 50-ies in the Donetsk coal basin salinity value of the mine waters did not exceed 1.5 – 2.0 g/dm³. As the depth of coal mining increased the water salinity increased too, reaching 4.0 – 5.0 g/dm³ in 1990. By the year of 2013 70 % of the mines discharged water with up to 3.0 mg/dm³ salinity, about 25 % of mines – with 3.0 – 5.0 mg/dm³, and 5 % of mines – with more than 5.0 mg/dm³ [1].

Problem statement

The weighted average salinity of ground waters in 1993 – 2013 increased from 2.1 to 2.3 g/dm³, while the area of groundwater with salinity greater than 3.0 g/dm³ doubled. Furthermore, the ratio of salts in ground waters changed too. If under inviolate hydro-geological conditions hydrogen ions prevailed, and the quantitative relationship between the main macro-components was as

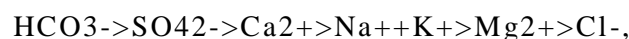

under the conditions of a considerable technogenic load, the dominant position is occupied by the sulfate ion. It is reasonable to suggest that the tendency towards an increase in salinity of mine waters is general and is observed in other coal mining regions too. Discharge of increased salinity waters into open reservoirs has not only led to an increase in water salinity in them but to an increase in salinity of deep ground waters as well, which were used to provide both the population and the food industry with high-quality drinking water. As a consequence, the cost of drinking water conditioning is increasing, and there is very little ecologically pure drinking water in the coal mining regions. If the problems of both treating mine waters and using their contaminants usefully are not solved in the other coal mining region in this country, the Lviv-Volyn coal basin, a similar situation may arise there too.

Attempts to solve the problem of mine waters have been taken for a long time, however, to date, neither in this country nor in the CIS there is not any single industrial installation of this type. In general, all the mine water treatment installations are based on the operating principles of mechanical and coagulation treatment [2]. The water treated from suspended solids is discharged into surface waters. Currently, there exist a number of ways of extensive treatment of mineralized waters, including reverse osmosis desalination and a further evaporation of the concentrate, and crystallization of dry salts [3]. However, the industrial real-

ization of the proposed method for mine waters is not reported by the developers. The reason for such a partial solution to the problem of treating mine waters is the complexity of water preparation for desalination and a difficulty in further processing of the reverse osmosis concentrate [4].

Technology of deep treatment of mine water

In the Lviv-Volyn coal basin, considerable coking coal deposits have been found. Currently, a mine is under construction here. Hydro-geologists carried out a forecast of the expected water composition of this mine (Table), and its volumetric flow, which will vary from 145 m³/h during the initial period to 133 m³/h during the period of stable work. Specificity of this region is that the specified amount of water with the expected salinity of 10 – 20 g/m³ can not be discharged into a surface water body.

Table. Expected composition of the water in Lubelskaya mine

Period of the mine operation	Water inflow, m ³ /h			Forecast results						
	Q	Q ₁	Q ₂	K, mg/dm ³	HCO ₃ ⁻ , mg/dm ³	SO ₄ ²⁻ , mg/dm ³	Cl ⁻ , mg/dm ³	Na ⁺ +K ⁺ , mg/dm ³	Ca ²⁺ , mg/dm ³	Mg ²⁺ , mg/dm ³
Initial	145.5	90.9	54.6	18.7	238.2	1909.8	9123.5	5465.0	891.4	327.4
Stable water inflow	132.8	49.8	83.0	11.7	346.2	1181.5	5569.8	3394.7	557.5	211.4
Basic ion composition, mEq/dm ³	300.693A/309.462K			–	3.903	39.788	257.0	237.609	44.57	27.283
Stable ion composition, mEq/dm ³	187.186A/193.088K			–	5.675	24.615	156.90	147.596	27.88	20.958

As can be seen from the above data, the water in Lubelskaya mine is of a complex chloride-sulfate sodium-calcium-magnesium character, making it virtually impossible to treat it by using any one of the known methods. We propose the technology of a complex treatment of this very mine water, which includes reagent treatment, reverse osmosis concentration and evaporation with crystallization. The essence of the technology proposed consists in the following (Fig. 1).

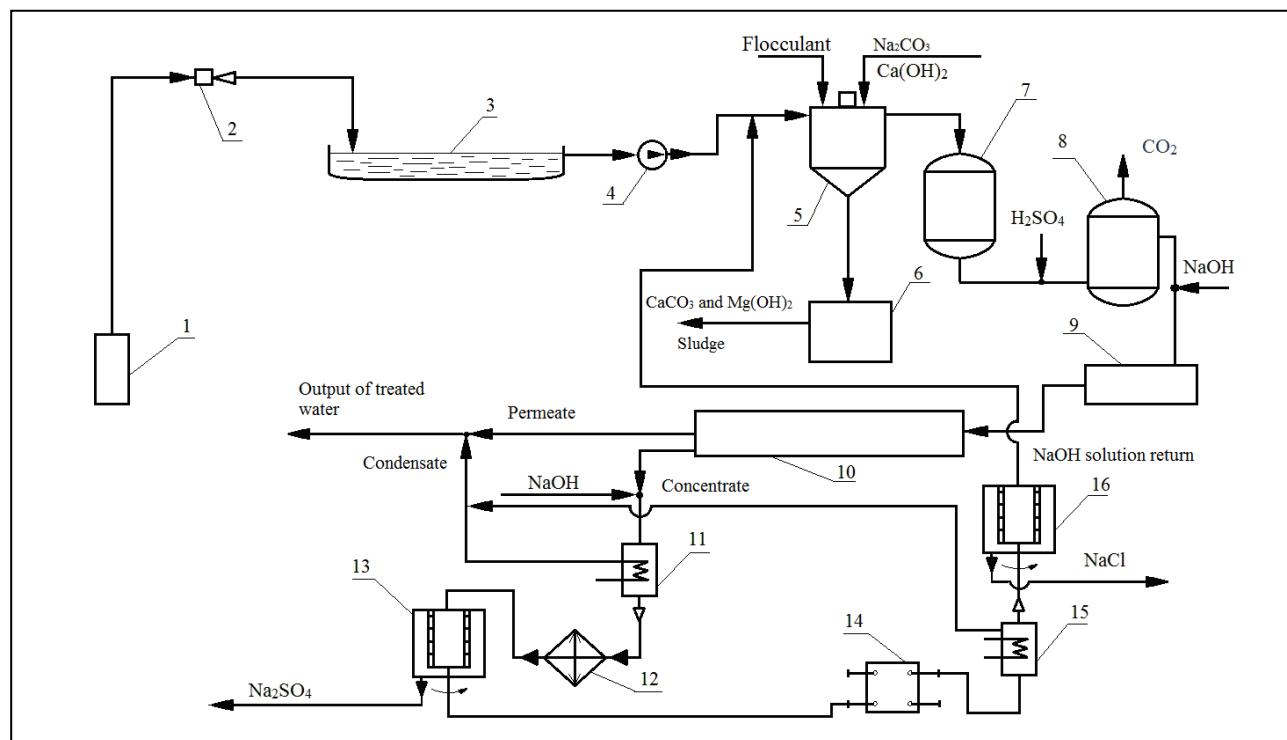

Fig. 1. Basic diagram of the system for mine water demineralization:

- 1 – mine pump; 2 – ejector; 3 – mine water well pond ; 4 – secondary recovery pump; 5 – contact clarifiers; 6 – filter press of the sludge coagulation; 7 – granular filter; 8 – decarbonizer; 9 – UV unit; 10 – reverse osmosis unit; 11 – first stage evaporators; 12 – crystallizer; 13 – centrifuge for sodium sulfate; 14 – recuperative heat exchanger; 15 – second stage evaporators; 16 – centrifuge for sodium chloride

Special pumps supply the mine water to the surface at a pressure of 0.3 – 0.4 MPa, where it is pumped through the ejectors mixing it with a large amount of air, with gaseous admixtures being puffed from the water, the former impeding the latter's treatment (hydrogen sulfide, etc.). At the same time, the water is saturated with aerial oxygen and goes to the mine water well pond. In this pond the water is kept for not less than 10 days. During this period of time, the water is completely oxidized, with iron, suspended solids and other unstable contaminants removed.

From the well pond, the water is sent for reagent treatment consisting in a successive realization of first coagulation and then soda-lime or electro-membrane softening. We have proposed to carry out both processes simultaneously in the VTI-160i contact clarifiers, using anionic and cationic organic flocculants. The process of coagulation-softening results in the formation of sludge consisting of both CaCO_3 and $\text{Mg}(\text{OH})_2$, as wastage. This sludge after compression and filtration by the filter press (6) becomes a calcium-magnesium raw material for the cement industry.

After being softened and filtrated in the granular filters, the water has a pH of 11 – 12. With such an environment reaction it is very difficult to membrane process. Therefore, before being fed into the modules of reverse osmosis the water is neutralized with a solution of sulfuric acid to pH 4. Then it is subjected to decarbonization in the decarbonizer, and afterwards neutralized with sodium hydroxide to pH 6.8. The total hardness of the water after the reagent softening shall not exceed 0.5 mEq/dm³. These parameters of raw water make it possible to carry out reverse osmosis desalination without adding special reagents – sedimentation inhibitors (so-called antiscalants). The use of antiscalants in the proposed scheme is extremely undesirable, since it will be followed by contamination of desalination products with phosphates and other harmful admixtures. Without using antiscalants the water with the said salinity and hardness could be concentrated by no more than 15 – 20 times.

The softened, decarbonated and neutralized water is supplied to the ultra-violate unit (9) to be sterilized and then to the reverse osmosis desalination unit. Here, under a pressure of 2.5 MPa about three-quarters of the water discharge are filtered through a membrane to form a permeate with salinity of 200 – 220 mg/dm³. The remaining water flows out of the modules as a concentrate with a total salinity of about 80,000 mg/dm³.

A solution of such a concentration can be further processed by evaporation only because with its further concentration by reverse osmosis there arises the risk of intensive deposition of hardness salts on the membranes. The pH value of the reverse osmosis concentrate will be 6.8. With the presence of a high concentration of chlorides in the solution (up to 30,000 mg/dm³), the said concentrate is a fairly aggressive liquid, and under such conditions at a high temperature only titanium is characterized by the desired stability. Evaporator units made of titanium will be too expensive. That was why we have provided the possibility of increasing the pH of the reverse osmosis concentrate to 10.0 – 11.0 by dosing small amounts of sodium hydroxide. Under such a reaction of the medium the X20 alloy steel possesses sufficient resistance.

In the first stage of the evaporator unit consisting of five film evaporators, the solution is evaporated to the total solids concentration of 22 %. The solution is then sent to the crystallizer where it is cooled to –10 °C. As this takes place, sodium sulfate is crystallized out of the solution in the form of mirabilite $\text{Na}_2\text{SO}_4 \cdot 10\text{H}_2\text{O}$. The mirabilite crystals are separated by the centrifuge from the mother liquor, and then washed with demineralized water cooled to 0 °C, packaged and shipped to customers, producing glass.

The mother liquor for crystallizing sodium sulfate is heated in the recuperative heat exchanger is then and sent to the second stage evaporators to separate the crystalline sodium chloride. Sodium chloride crystals are separated in the centrifuge and afterwards sold to be used both in water softening processes and municipal services. The remaining mother liquor for crystallizing sodium, equaling 1 % of the raw water is directed to contact clarifiers for softening. Thus, it is possible to obtain a relatively pure sodium chloride by returning most of the admixtures of sodium sulfate and sodium hydroxide for use in the processes of softening and concentrating water, and crystallizing salts.

The reserve osmosis permeate is mixed with the condensate of evaporator units. Its mineralization, in accordance with calculations, will be 100 – 120 mg/dm. The water will have a temperature up of to 50 – 55 °C. This water is supposed to be used for supplying the mine with hot water and meeting the sanitary requirements of the enterprise in clean water. The surplus can be used as feed water for low-pressure boilers or heating systems. It can also be used as partly demineralized water during water treatment for TPPs and

CHPs. Thus, the proposed technology for demineralizing mine water can be considered practically non-waste, since all the macro contaminants are extracted from the water in the form of valuable raw materials.

This technology, after appropriate modification, can also be suitable for zero-discharge treatment of wastewater of food, oil and gas, chemical, metallurgical and other industries. If the wastewater contains significant concentrations of organic admixtures, the mother liquor, after crystallization of mineral salts, can be used to prepare for hydrocavitation preparation of composite fuel.

Based on the obtained results, a project (stage II) of the complex for drainless water treatment for Lubelskaya mine has been implemented, the working documentation being prepared to be released.

Conclusions

1. The existing technologies for mine water treatment have been analyzed. It has been shown that they mainly imply clarification and mechanical cleaning. Treated in this way, mine waters have an increased mineralization and, when discharged into surface water reservoirs, they pollute them.

2. An integrated drainless technology for deep treatment of mine waters is proposed. The technology consists in demineralization and extraction of contaminants as marketable products for use in the construction industry, glass production, municipal services, etc.

3. Based on the obtained results, a project (stage II) of the complex for drainless water treatment for Lubelskaya mine has been implemented, the working documentation being prepared to be released.

References

1. Galetsky L. S. , Slyadnev E. A., Yakovlev V. A. Ecological and Geological Aspects of the Formation of the Quality of Groundwater in the Mining and Industrial Areas of Central Donbass. *Aqua-Ukraine 2006*. Issues of IV Intern. Water Forum, (Kiev, 19–21 Sept. 2006). Kiev, 2006. P. 96–100.
2. Frog B. N., Levchenko A. P. Water Treatment: Manual for Universities. M.: Moscow State University Publishing House, 1996. 680 p.
3. Starikov E. N. Membrane Technologies for Wastewater Treatment. *Water 2007*. Issues of II Intern. Conf. (Moscow, 21 May 2007), Moscow, 2007. P. 98–107
4. Zapolskyi A. K., Mishkova-Klimenko N. A., Astrelin I. M., Brick M. T., Hvozdyk P. I., Kniazkova T. V. Basics of Physical/Chemical Technologies of Waste Water Treatment: Manual. Kyiv: Libra. 2000. 552 p.

Received 2 March 2018